

# Digital Outputs

This document describes the characteristics of digital outputs. It also describes how to test and use it.

## Digital Output Hardware

The digital output (Dout) is a LOW SIDE type with internal 10 KOhm weak pull-up resistor.  
The Dout stage is as reported below:

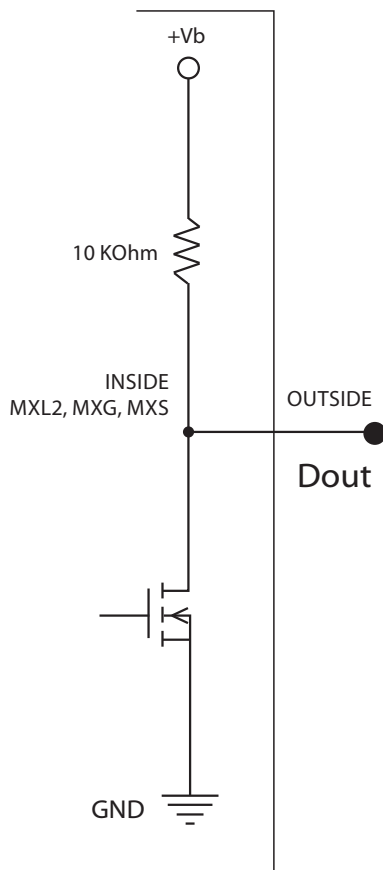

+Vb is tied internally at battery voltage (nominally 12V) and you don't have to care about it.

When the driver is OFF (output not active), the Dout output is pulled high to battery voltage through a 10 KOhm resistor. This configuration is not intended to drive loads because the current is limited to 1 mA approximately.

When the driver is ON (output active), the Dout output is pulled LOW to GND and it can sink currents up to 1 Amp.

The typical use of the Dout output is to drive a lamp or a a relay.

The load must be connected to the digital outputs as indicated below, then it is possible to obtain the desired behaviour configuring the dash logger with RS3.

# Digital Outputs

## Connecting examples

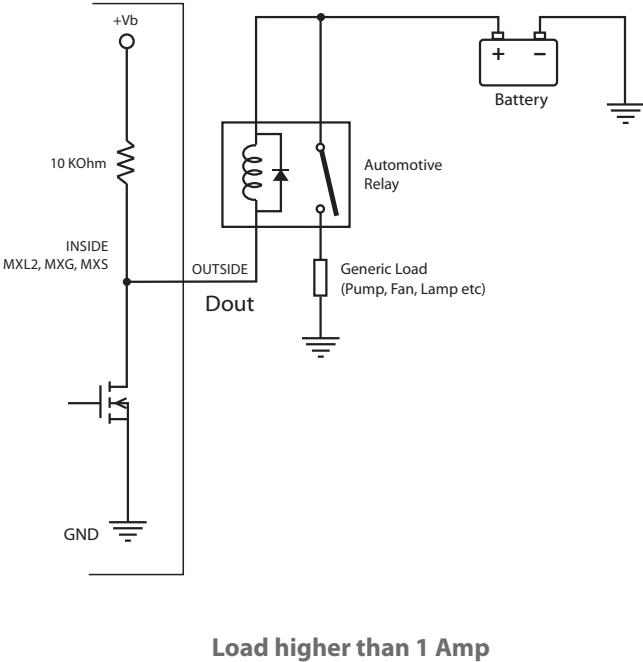
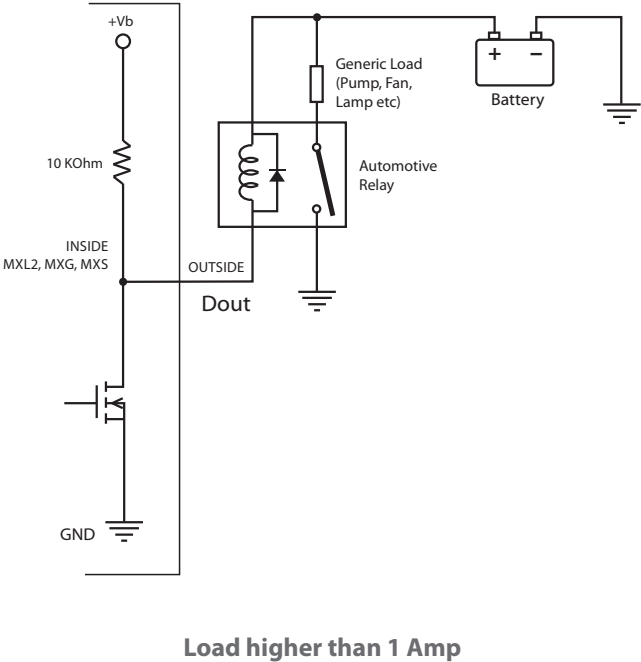
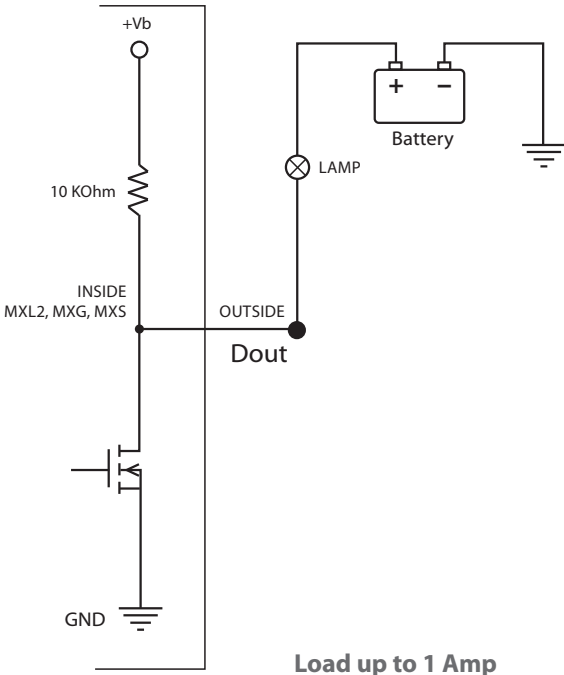

# Digital Outputs

### Configuration

Use RS3 to configure the digital outputs. In the Shift Lights and Alarms tab, define a condition to meet and an action to perform. In the example below Channel04 is a 0-5000mV input.

When Channel04 input is lower than 2500mV the LED4 will be OFF, the digital out 1 will be LOW (Dout1 closed to GND, 1A max current sinked) while the digital out 2 will be HIGH (Dout2 closed to Battery voltage, no current to the load).

When Channel04 input is higher than 2500mV the LED4 will be ON (Red), the digital out 1 will be HIGH (no current to the load) while the digital out 2 will be LOW (Dout2 closed to GND, 1A max current sinked).

